

INDUSTRIAL DIESEL ENGINE

KUBOTA 05-SERIES (3-cylinder)

D1005-E3B



RATED POWER

17.5 kW/3000 rpm

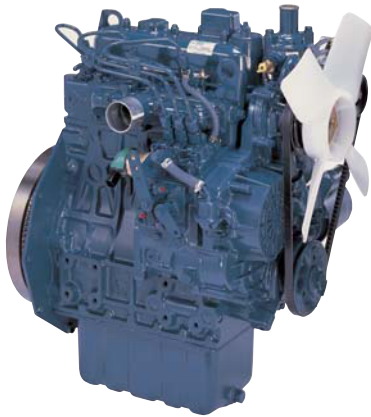

PERFORMANCE CURVE

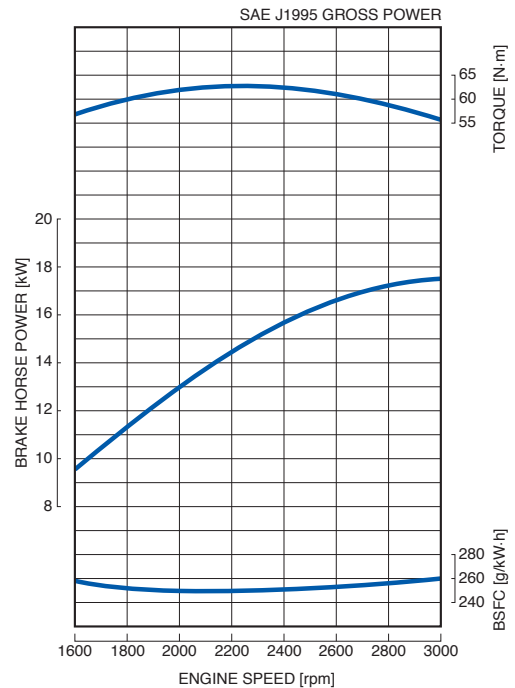

FEATURES with BENEFITS

Emissions

- The D1005 engine complies with EPA Tier 4 emissions regulations. These are the most stringent emissions regulations in the world in this class.

Durable Power

- The Kubota 05-Series is an established leader in its horsepower range and has been the preferred power source of various industrial equipment manufacturers.
- The D1005 engine offers a seamless transition from Tier 2 to Tier 4 by maintaining the same footprint and hardware mounting points with only slight performance changes from the Tier 2 engine.

Clean and Quiet Power

- Kubota's original E-TVCS (Three Vortex Combustion System) has been improved. The combustion chamber and piston recess were optimized to achieve a 50% lower particulate matter (PM) level.

GENERAL SPECIFICATION

Model		D1005-E3B
Emission Regulation		Tier 4
Type		Vertical 3-cycle Liquid Cooled Diesel
Number of Cylinders		3
Bore	mm (in)	76 (2.99)
Stroke	mm (in)	73.6 (2.90)
Displacement	L (cu.in)	1.001 (61.08)
Combustion System		Indirect Injection
Intake System		Naturally Aspirated
Maximum Speed	rpm	3000
Output: SAE J1995 Gross Power	kW	17.5
	hp	23.5
	ps	23.8
Direction of Rotation		Counterclockwise Viewed on Flywheel
Oil Pan Capacity	L (gal)	5.1 (1.35)
Starter Capacity	V-kW	12-1.2 [US] / 12-1.4 [EU]
Alternator Capacity	V-A	12-40
Length	mm (in)	497.8 (19.60)
Width	mm (in)	396.0 (15.59)
Height (1)	mm (in)	602.0 (23.70)
Height (2)	mm (in)	227.6 (8.96)
Dry Weight	kg (lb)	93.0 (205.0)

*Specification is subject to change without notice.

*Dry weight is according to Kubota's standard specification.

When specification varies, the weight will vary accordingly.

*SAE J1995 Gross Power: 1-hour rating based on engine without cooling fan, air cleaner and muffler, with alternator.

DIMENSIONS

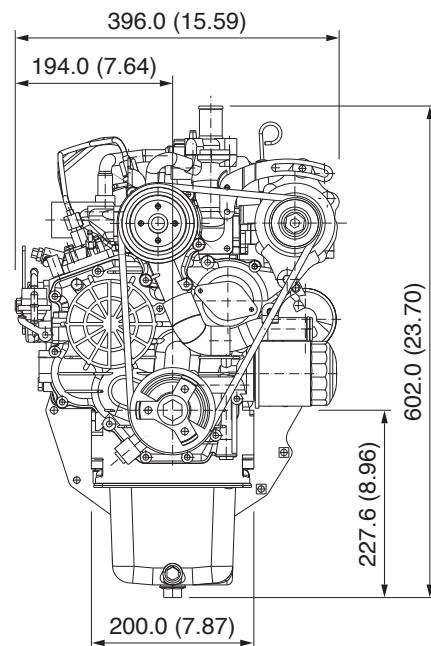
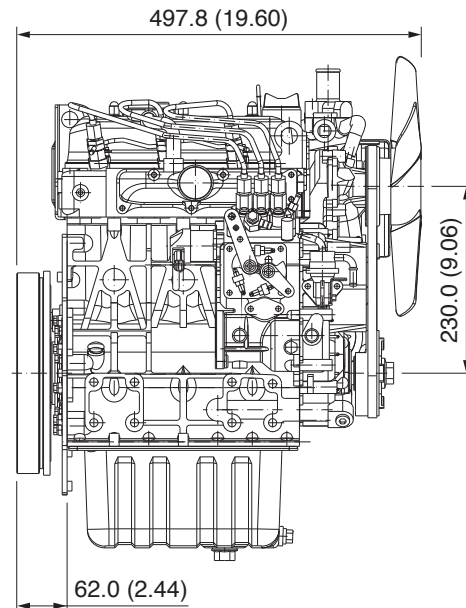

I.M.A. H.-D. Gröschler GmbH
 Westring 41
 Industriegebiet Asemissen
 D-33818 Leopoldshöhe

Phone: +49 52 02 / 98 75 - 0
 Fax: +49 52 02 / 98 75 - 15
 Internet: www.i-m-a.de
 E-mail: info@i-m-a.de

