



INDUSTRIAL DIESEL ENGINE

KUBOTA 07-SERIES (4-cylinder)

V3307-DI-T-E3B



RATED POWER

55.4 kW/2600 rpm



PERFORMANCE CURVE

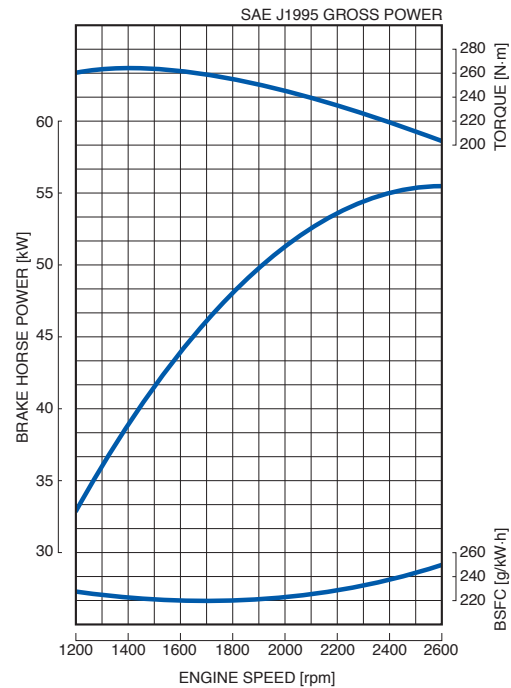

FEATURES with BENEFITS

New Concept

- The Kubota 07-Series is a totally new concept in engine design developed with various requirements necessary for a wide range of industrial applications.
- Kubota's unique cylinder block design was developed using Kubota's original casting technology allowing for a larger displacement within the current 2.4 L compact engine package.
- The improved cooling system with a main water gallery and water passages between cylinder bores as a countermeasure against heat load provides high power density, superior endurance and a reliable Kubota 07-Series.
- The Kubota 07-Series completes Kubota's seamless range up to 100 hp.

Emissions

- The NEW Kubota 07-Series engines have been designed to comply with EPA Interim Tier 4 emissions regulations, which are the most stringent in this size range. The Kubota 07-Series engines also comply with EU Stage 3A requirements. The Kubota 07-Series engines offer the benefit of one year longer validity than Tier 3. Therefore, these engines are good through the end of 2012 in both the North American and European markets, which would save engineering resources for the future Tier levels.
- Meeting emission regulations with minimal additional required devices: NOx is reduced only by mechanical means such as a compactly designed cooled exhaust gas recirculation (EGR) system.

Clean and Quiet Power

- Kubota's original E-CDIS (Center Direct Injection System) combustion system, renowned for clean combustion in the Kubota V3 (DI) Series, has been renovated. The fuel injection pressure was increased and the combustion chamber was redesigned to achieve a 25% lower particulate matter (PM) level, resulting in a better condition when compared to engines that only meet EPA Tier 3 regulations in this class.
- These new engines have been designed to reduce transmitted vibrations and radiated sound, resulting in lower noise levels. Operator and environmentally friendly, the Kubota 07-Series begins a new era of Kubota's engine design.

Option

- A Side PTO option is available. The Kubota 07-Series engines offer up to 100% power take-off (PTO) from a gear train located on the flywheel side designed for compact positioning of PTO hydraulic devices. In response to the trend of increasing hydraulic control devices in industrial machines, it is possible to install up to three hydraulic pumps with different capacities.
- Fan positions are available in two heights to adapt to various equipment configurations.

GENERAL SPECIFICATION

Model		V3307-DI-T-E3B
Emission Regulation		Interim Tier 4 / Stage 3A
Type		Vertical 4-cycle Liquid Cooled Diesel
Number of Cylinders		4
Bore	mm (in)	94 (3.70)
Stroke	mm (in)	120 (4.72)
Displacement	L (cu.in)	3.331 (203.3)
Combustion System		Direct Injection
Intake System		Turbocharged
Maximum Speed	rpm	2600
Output: SAE J1995 Gross Power	kW	55.4
	hp	74.3
	ps	75.3
Direction of Rotation		Counterclockwise Viewed on Flywheel
Oil Pan Capacity	L (gal)	11.0 (2.91)
Starter Capacity	V-kW	12-3.0
Alternator Capacity	V-A	12-45
Length	mm (in)	674.0 (26.54)
Width	mm (in)	506.0 (19.92)
Height (1)	mm (in)	739.0 (29.09)
Height (2)	mm (in)	226.5 (8.92)
Dry Weight	kg (lb)	268 (590.8)

*Specification is subject to change without notice.

*Dry weight is according to Kubota's standard specification.

When specification varies, the weight will vary accordingly.

*SAE J1995 Gross Power: 1-hour rating based on engine without cooling fan, air cleaner and muffler, with alternator.

DIMENSIONS

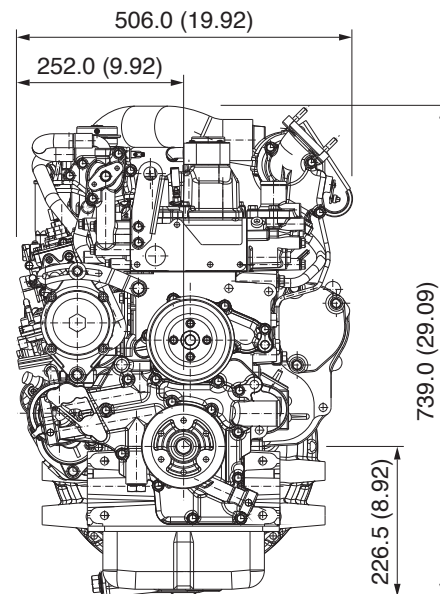
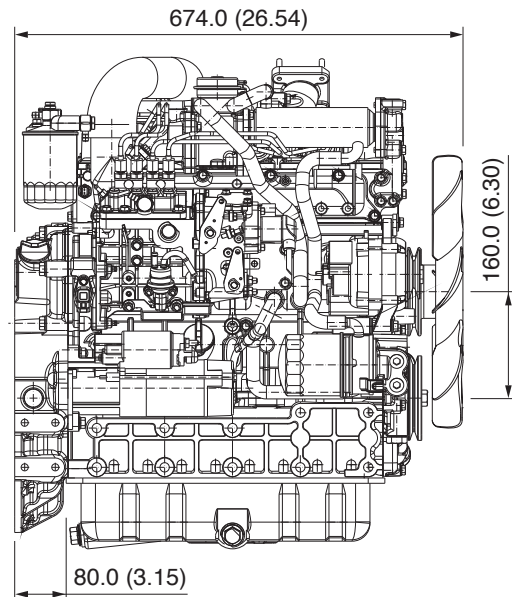

I.M.A. H.-D. Gröschler GmbH
Westring 41
Industriegebiet Asemissen
D-33818 Leopoldshöhe

Phone: +49 52 02 / 98 75 - 0
Fax: +49 52 02 / 98 75 - 15
Internet: www.i-m-a.de
E-mail: info@i-m-a.de

