

INDUSTRIAL DIESEL ENGINE

KUBOTA SUPER MINI SERIES (3-cylinder)

D902-E3B



RATED POWER

16.1 kW/3200 rpm



PERFORMANCE CURVE

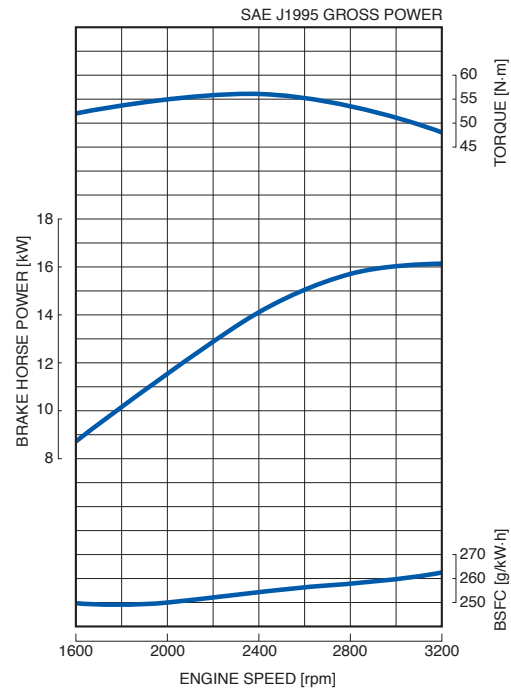

FEATURES with BENEFITS

Emissions

- Kubota Super Mini Series, the most compact multi-cylinder liquid cooled industrial diesel engines, complies with EPA Tier 4 emissions regulations. These are the most stringent emissions regulations in the world in this class.

Durable Power

- The D902 engine delivers the highest output within the Kubota Super Mini Series engines.
- By expanding the bore and stroke, Kubota increased engine displacement, while maintaining the same footprint as the D722 engine. By adopting an extended shallow oil pan, the engine height is lower than the D722 engine, providing a compact engine package.
- The cooling water passages between the cylinder bores, using Kubota's original casting technology as a countermeasure against heat load of high power density, provides both superior endurance and reliable engine characteristics.
- This engine offers a seamless transition from Tier 2 to Tier 4 by totally maintaining the same performance and physical characteristics of the previous Tier 2 engines.
- Alternative fuel engines, WG972 (Gasoline) and DF972 (Dual Fuel: Gasoline / LPG) are available with the same footprint as the D902 engine.

Clean and Quiet Power

- Kubota's original E-TVCS (Three Vortex Combustion System) has been improved. The piston recess was optimized to achieve a 50% lower particulate matter (PM) level in such a small size range.
- The half-float valve cover and MoS₂ coated pistons reduce noise levels and provide reduced transmitted vibration from the valve area for better noise characteristics.

GENERAL SPECIFICATION

Model		D902-E3B
Emission Regulation		Tier 4
Type		Vertical 3-cycle Liquid Cooled Diesel
Number of Cylinders		3
Bore	mm (in)	72 (2.83)
Stroke	mm (in)	73.6 (2.9)
Displacement	L (cu.in)	0.898 (54.80)
Combustion System		Indirect Injection
Intake System		Naturally Aspirated
Maximum Speed	rpm	3200
Output: SAE J1995 Gross Power	kW	16.1
	hp	21.6
	ps	21.9
Direction of Rotation		Counterclockwise Viewed on Flywheel
Oil Pan Capacity	L (gal)	3.7 (0.98)
Starter Capacity	V-kW	12-1.2
Alternator Capacity	V-A	12-40
Length	mm (in)	467.1 (18.40)
Width	mm (in)	420.5 (16.6)
Height (1)	mm (in)	544.1 (21.42)
Height (2)	mm (in)	204.0 (8.03)
Dry Weight	kg (lb)	72.0 (158.8)

*Specification is subject to change without notice.

*Dry weight is according to Kubota's standard specification. When specification varies, the weight will vary accordingly.

*SAE J1995 Gross Power: 1-hour rating based on engine without cooling fan, air cleaner and muffler, with alternator.

DIMENSIONS

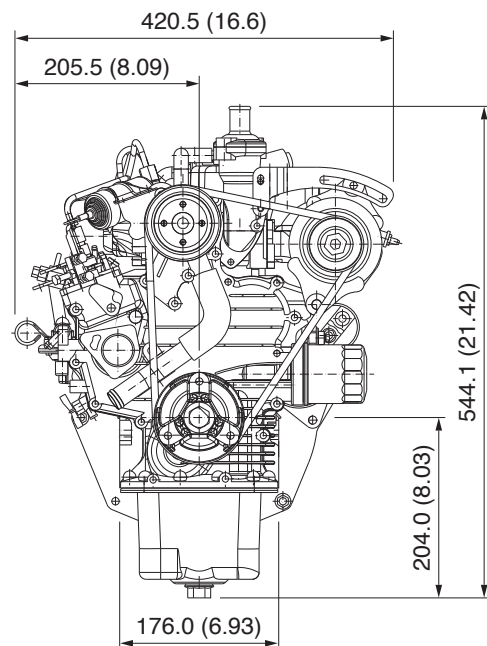
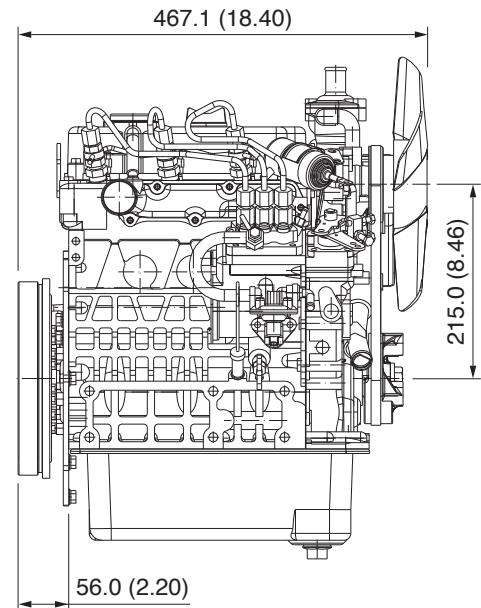

I.M.A. H.-D. Gröschler GmbH
Westring 41
Industriegebiet Asemissen
D-33818 Leopoldshöhe

Phone: +49 52 02 / 98 75 - 0
Fax: +49 52 02 / 98 75 - 15
Internet: www.i-m-a.de
E-mail: info@i-m-a.de

