



INDUSTRIAL DIESEL ENGINE

KUBOTA V3-SERIES (4-cylinder)

V3600-T-E3B



RATED POWER

63.0 kW/2600 rpm

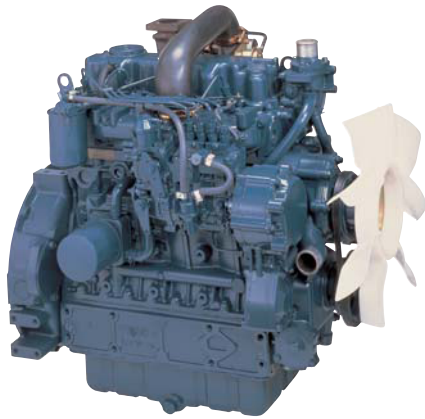

PERFORMANCE CURVE

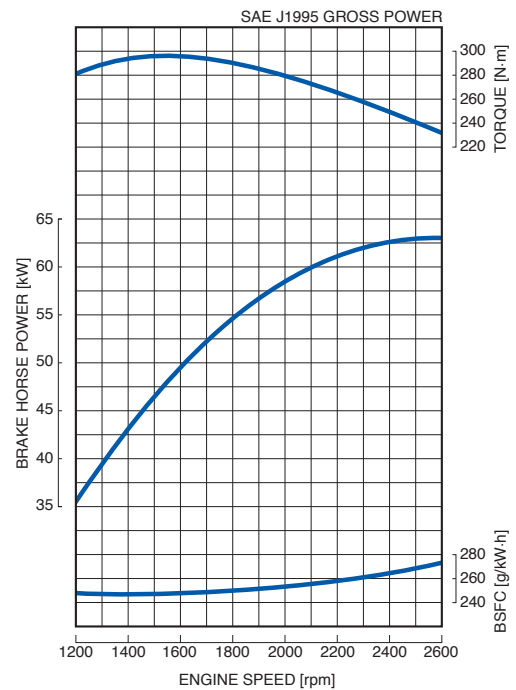

FEATURES with BENEFITS

Emissions

- The Kubota V3600 Turbocharged engine complies with EPA Tier 3 and EU Stage 3A emissions regulations effective through the end of 2011 in both the North American and European markets.
- Utilizing the low NOx characteristics of IDI engines, the V3600-T engine complies with the latest emissions regulations above the 56kW range without devices such as a cooled exhaust gas recirculation (EGR) system.

Durable Power

- The Kubota V3600-T engine is a new high power density engine with the same footprint as the V3300 engine, however with a larger displacement.

Clean and Quiet Power

- Kubota's original E-TVCS (Three Vortex Combustion System) has been improved. The airflow, combustion chamber and piston recess were optimized to meet the new NOx level of this class.

Option

- Fan positions are available in two heights to adapt to various equipment configurations.

GENERAL SPECIFICATION

Model		V3600-T-E3B
Emission Regulation		Tier 3 / Stage 3A
Type		Vertical 4-cycle Liquid Cooled Diesel
Number of Cylinders		4
Bore	mm (in)	98 (3.86)
Stroke	mm (in)	120 (4.72)
Displacement	L (cu.in)	3.620 (220.9)
Combustion System		Indirect Injection
Intake System		Turbocharged
Maximum Speed	rpm	2600
Output: SAE J1995 Gross Power	kW	63.0
	hp	84.5
	ps	85.7
Direction of Rotation		Counterclockwise Viewed on Flywheel
Oil Pan Capacity	L (gal)	13.2 (3.49)
Starter Capacity	V-kW	12-3.0
Alternator Capacity	V-A	12-60
Length	mm (in)	745.0 (29.33)
Width	mm (in)	538.5 (21.20)
Height (1)	mm (in)	794.0 (31.26)
Height (2)	mm (in)	257.0 (10.12)
Dry Weight	kg (lb)	275 (606.3)

*Specification is subject to change without notice.

*Dry weight is according to Kubota's standard specification.

When specification varies, the weight will vary accordingly.

*SAE J1995 Gross Power: 1-hour rating based on engine without cooling fan, air cleaner and muffler, with alternator.

DIMENSIONS

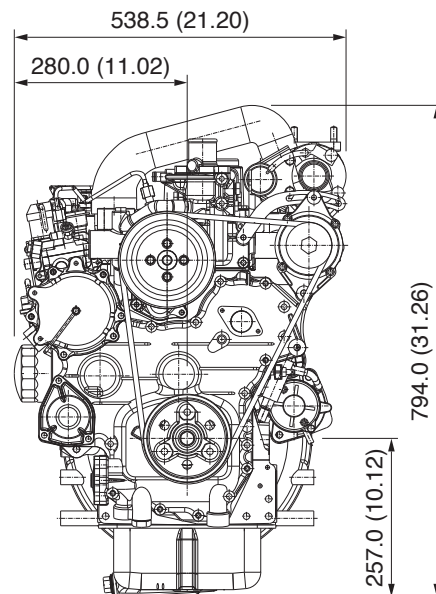
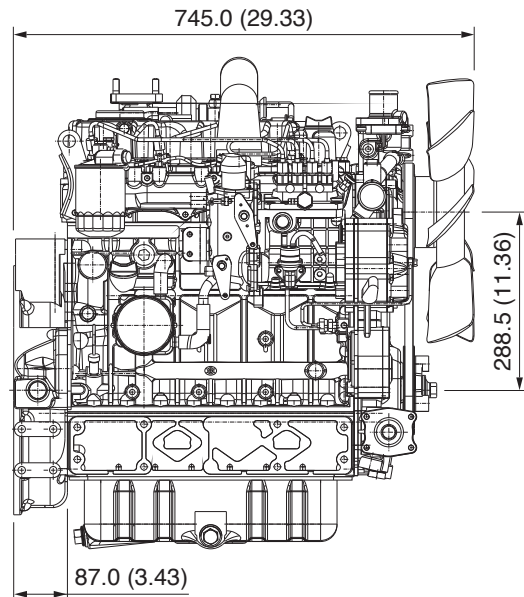

I.M.A. H.-D. Gröschler GmbH
 Westring 41
 Industriegebiet Asemissen
 D-33818 Leopoldshöhe

Phone: +49 52 02 / 98 75 - 0
 Fax: +49 52 02 / 98 75 - 15
 Internet: www.i-m-a.de
 E-mail: info@i-m-a.de

