

INDUSTRIAL DIESEL ENGINE

KUBOTA V3-SERIES (4-cylinder)

V3800DI-T-E3B



RATED POWER

72.8 kW/2600 rpm

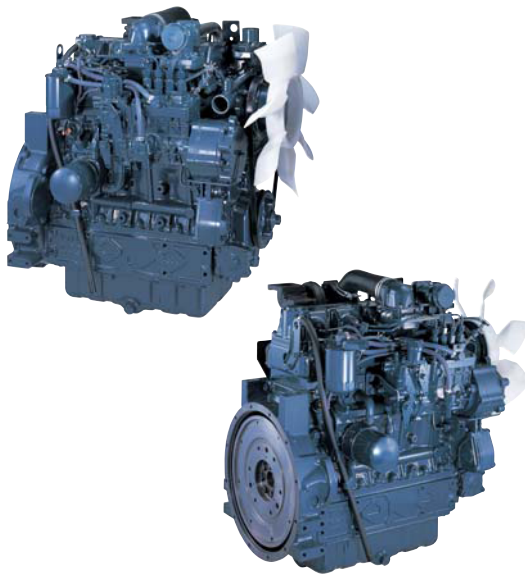

PERFORMANCE CURVE

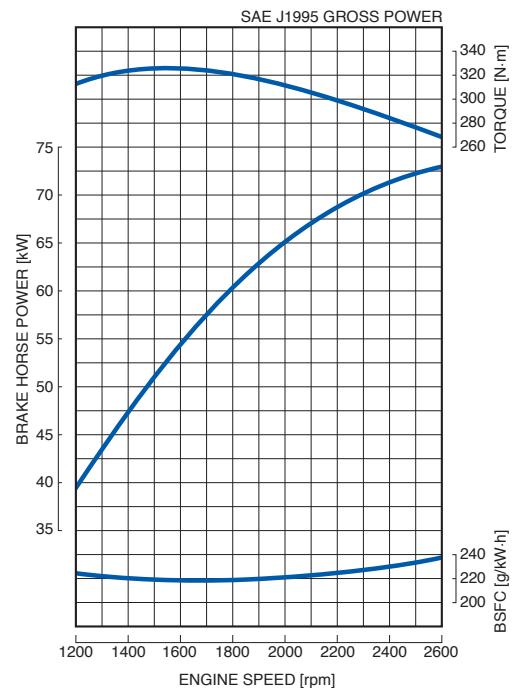

FEATURES with BENEFITS

Emissions

- The Kubota V3800 direct injection turbocharged engine complies with EPA Tier 3 and EU Stage 3A emissions regulations effective through the end of 2011 in both the North American and European markets.
- Meeting emissions regulations with minimal additional required devices: NOx is reduced only by mechanical means such as a cooled exhaust gas recirculation (EGR) system.

Durable Power

- The V3800DI-T engine has the highest output, under the 75kW range, in Kubota's industrial diesel engine line-up. This engine does not require any electronic control devices to comply with the latest emissions regulations.

Clean and Quiet Power

- Kubota's original E-CDIS (Center Direct Injection System) combustion system, renowned for clean combustion, has been updated. Fuel injection pressure was increased to meet the new NOx level of this class.
- The half-float valve cover and MoS₂ coated pistons reduce noise levels and provide reduced transmitted vibration from the valve area for better noise characteristics.

Option

- The Kubota V3800DI-T engine offers side power take-off (PTO), in response to the trend of increasing hydraulic control devices used in industrial machines. It is possible to install up to two hydraulic pumps.
- Fan positions are available in two heights to adapt to various equipment configurations.

GENERAL SPECIFICATION

Model		V3800DI-T-E3B
Emission Regulation		Tier 3 / Stage 3A
Type		Vertical 4-cycle Liquid Cooled Diesel
Number of Cylinders		4
Bore	mm (in)	100 (3.94)
Stroke	mm (in)	120 (4.72)
Displacement	L (cu.in)	3.769 (230.0)
Combustion System		Direct Injection
Intake System		Turbocharged
Maximum Speed	rpm	2600
Output: SAE J1995 Gross Power	kW	72.8
	hp	97.6
	ps	99.0
Direction of Rotation		Counterclockwise Viewed on Flywheel
Oil Pan Capacity	L (gal)	13.2 (3.49)
Starter Capacity	V-kW	12-3.0
Alternator Capacity	V-A	12-90
Length	mm (in)	745.0 (29.33)
Width	mm (in)	549.0 (21.61)
Height (1)	mm (in)	794.0 (31.26)
Height (2)	mm (in)	257.0 (10.12)
Dry Weight	kg (lb)	288 (634.9)

*Specification is subject to change without notice.

*Dry weight is according to Kubota's standard specification.
When specification varies, the weight will vary accordingly.

*SAE J1995 Gross Power: 1-hour rating based on engine without cooling fan, air cleaner and muffler, with alternator.

DIMENSIONS

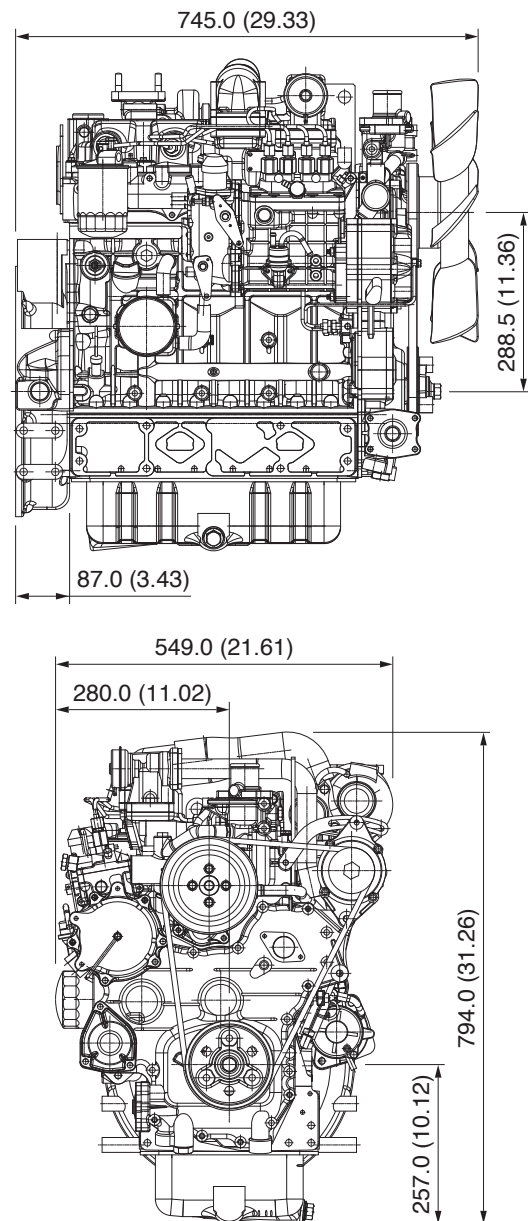

I.M.A. H.-D. Gröschler GmbH
Westring 41
Industriegebiet Asemissen
D-33818 Leopoldshöhe

Phone: +49 52 02 / 98 75 - 0
Fax: +49 52 02 / 98 75 - 15
Internet: www.i-m-a.de
E-mail: info@i-m-a.de

